

## Palletizing with the use of industrial robots:

Drewmax has been creating and launching projects for palletizing with the use of industrial robots a Japanese company Yaskawa.

Depending of project, the robot has four or six axes of arm movement within the range of up to 3159 mm.

The end of the robot arm is equipped with a special type of gripper which is designed and manufactured by our company.

The gripper is adapted to pick up rigid containers (cardboard boxes, buckets, bottles) or bags from the roll conveyor.

The robot takes bags or boxes from conveyor and places them on a pallet. The same gripper can also take pallets or carton separators from a designated stock.

It is also possible to equipped palletizing station with an automatic stock of empty pallets. The construction of stock is prepare to magazine 15 pieces. The stock unit dispenses individual pallets in an automatic cycle.

Loaded pallets can be transported straight to the automatic wrapper by the roll conveyor – we avoid problems connected with transporting a pallet prior to securing it with foil.



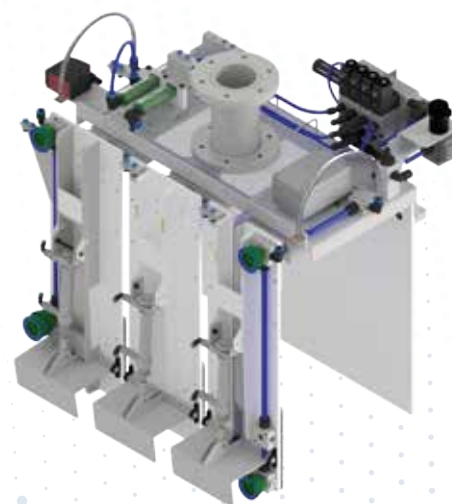
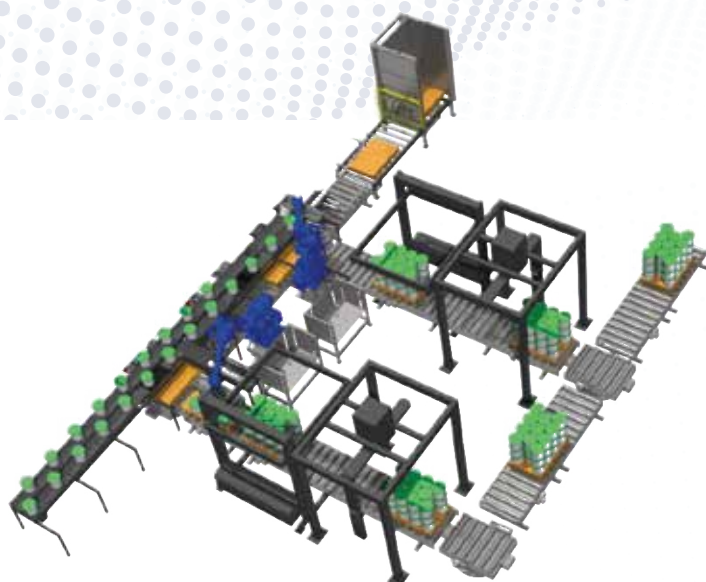
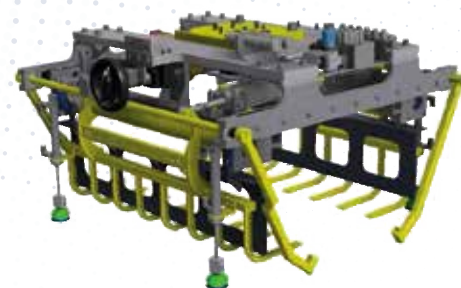
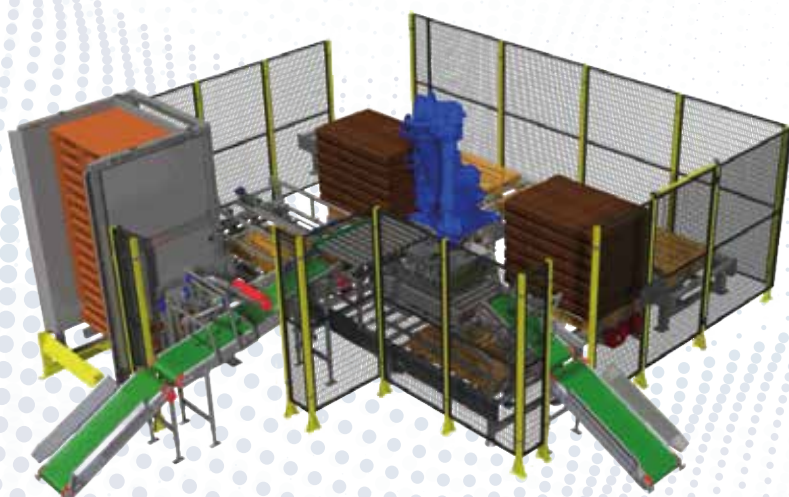

## Basic subassemblies of the appliance:

- Industrial robot Yaskawa
- Robot gripper
- Robot footing
- Special roller conveyor for the gripper
- Full pallet output conveyor
- Operator's control panel
- Protection fence

## Optional equipment:

- Empty pallets magazine
- Cardboard separators magazine
- Checkweigher with an automatic bags discriminator

