

Big-Bag filling systems

Drewmax company has on offer a series of appliances for packing products into four-tap Big-Bag type bags with the weight from **100kg** to **1500kg**. Depending on the needs, capacity, requirements, the offered machines differ with regard to construction and capacity.



The WBB pallet scales are the simplest in the series of appliances for packing **Big-Bag bags** (four-handle type bags). Its simple construction and easiness of use made it the machine most frequently chosen by our Customers.

The offered scales combined with an appropriate feeder become a semi-automatic weighing and packaging appliance.

The structure of the scales allows them to promptly adapt to a proper bag size and the tight closing system in connection with the dust removal installation prevents dust release at the moment of filling a bag.



The WBB2 pallet scales are an advanced appliance for filling **Big-Bag bags** (four-handle type bags).

Due to complex structure, bags with large dimensions can be packed on the presented machine, at the same time maintaining the easiness of operation.



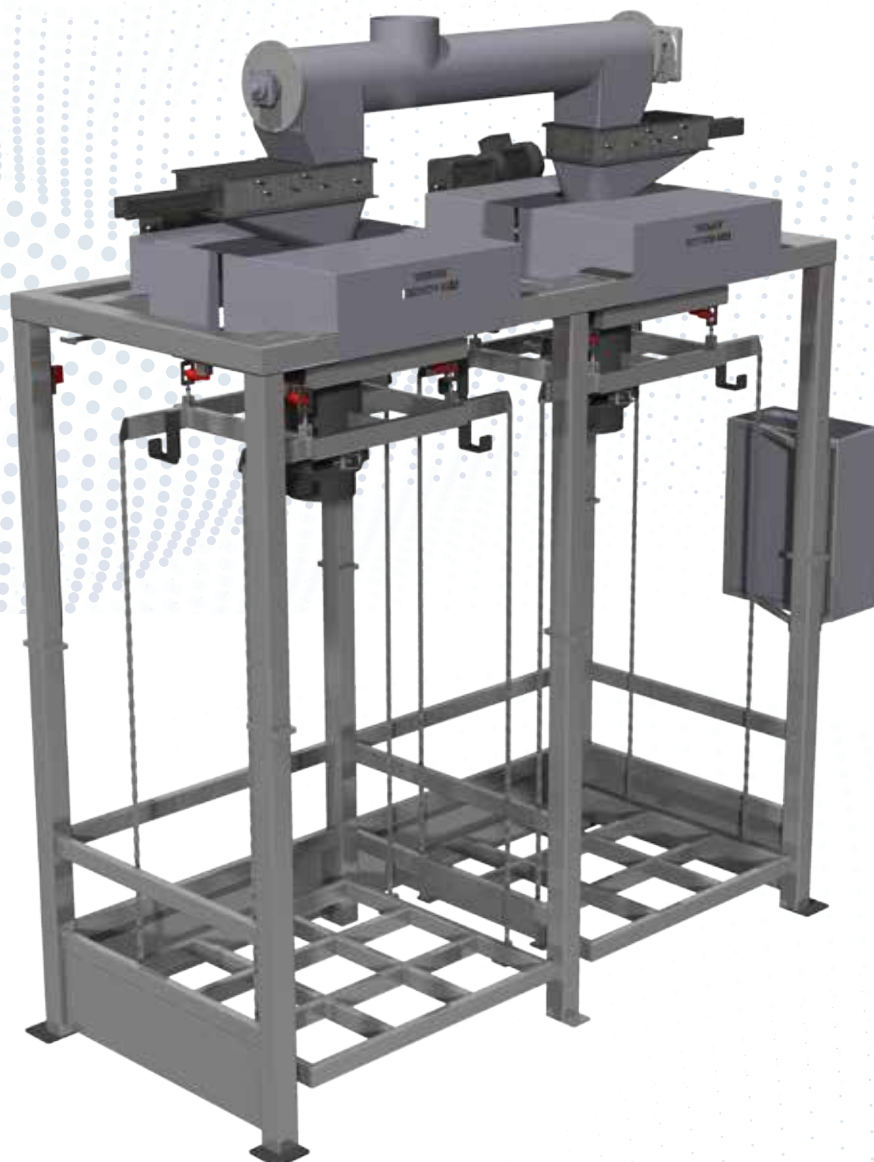

Scales for Big-Bag bags type WBB2

The appliance is equipped with a lifting / lowering system – a bag is automatically lifted for the time of pouring in order to be tightened, and after it is filled, it is lowered, thanks to which disconnecting it from the pouring spot becomes even easier.

The construction of the WBB2 scales allows any detector to be mounted above the pouring spot. The appliance can also be extended with an additional module, which considerably influences the capacity of the scales.

